

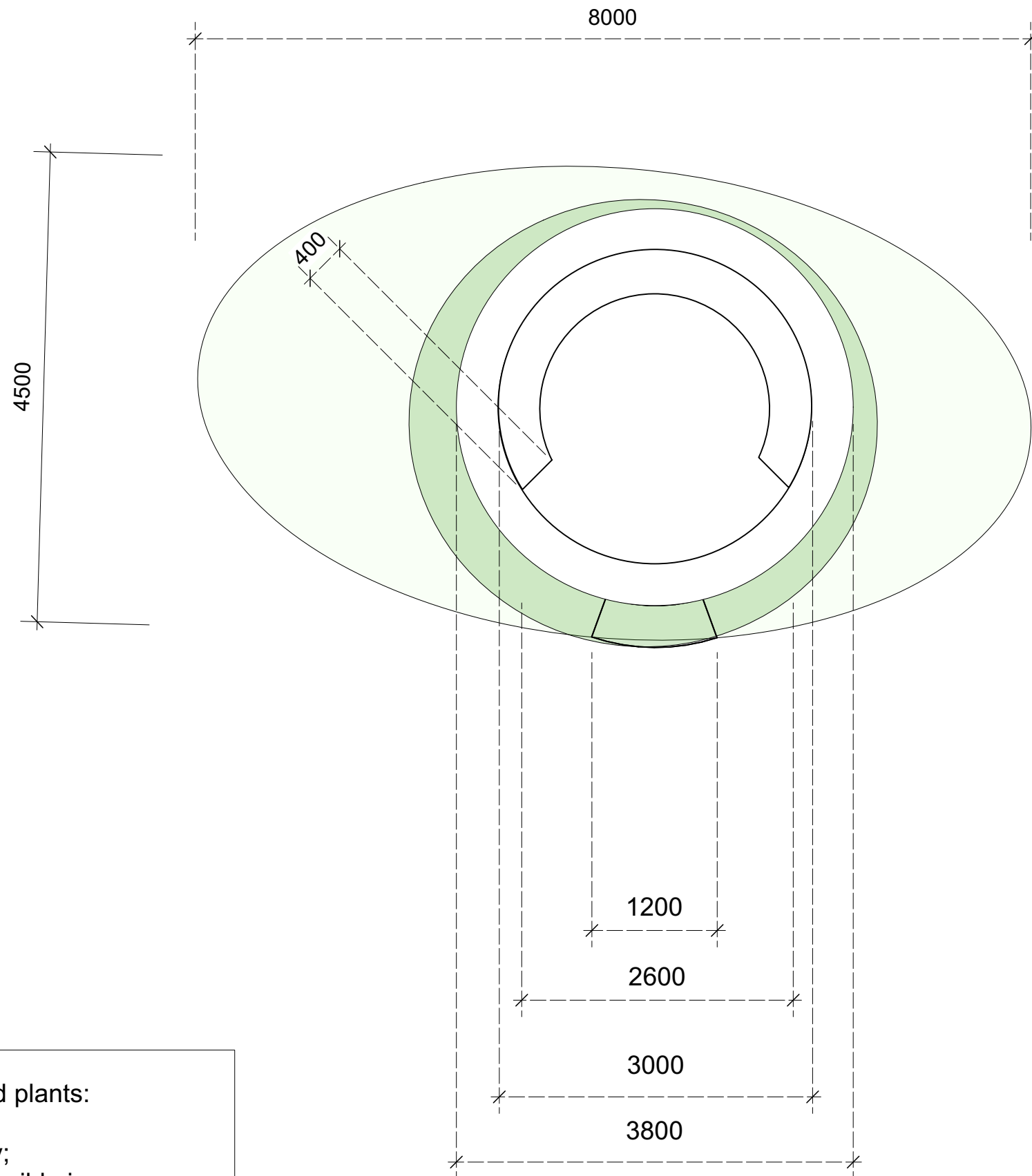

Garden of Serenity



Suggested plants:

Boston ivy;
 Canadian wild ginger;
 Blue moon woodland phlox

A gazebo covered with Boston ivy, surrounded by a circle of Canadian wild ginger, within a larger oval of Blue Moon woodland phlox.

This garden offers a peaceful pause, providing a space for introspection and meditation. It creates an immersive experience, where visitors feel as if stepping into a secret, magical place.

The vines create shade. The woodland phlox invites bees and butterflies. The gazebo, like a green cocoon, encapsulates the visitor. Looking outward through the green invites a sense of renewed connection to nature.

The natural, timeless, organic ambiance of this garden helps the visitors reconnect to the beauty of the natural world. It provides a space to reflect on the possibilities within their own lives, encouraging them to nurture their dreams, and to approach the world feeling refreshed and rejuvenated, with a renewed sense of harmony and wonder.

The plants are native to North America, perennial, and hardy for climate zone 4B. They can be replanted elsewhere after the exhibition ends. The gazebo's natural materials (lumber and stone tiles) can be easily repurposed or recycled.

Garden of Serenity

Top/Plan
 (preliminary drawing; Nov. 2023)

Scale 1:50

Page 1 of 4

note: detailed technical drawings will be provided if needed

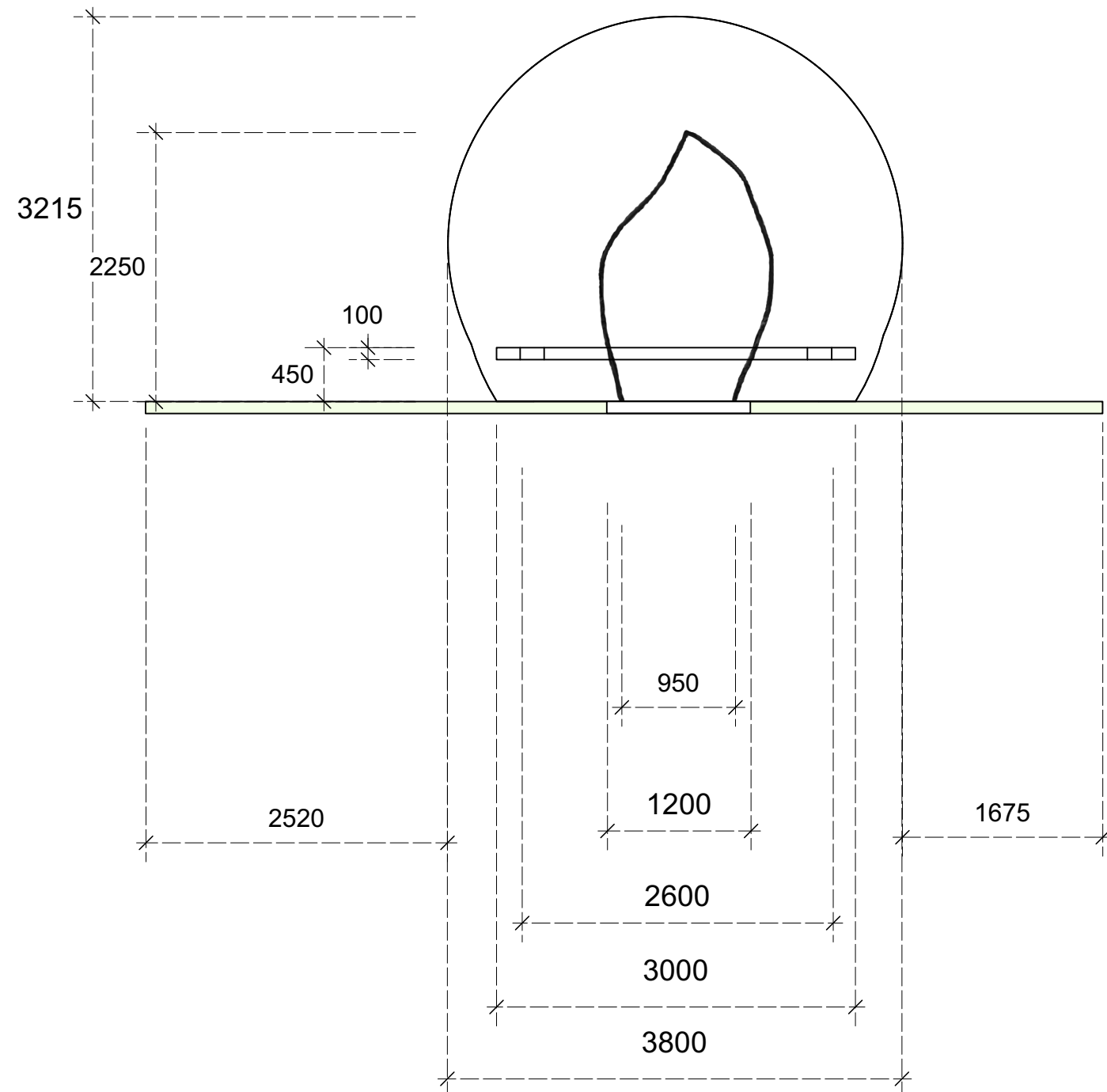

Suggested plants:

Boston ivy;
 Canadian wild ginger;
 Blue moon woodland phlox

A gazebo covered with Boston ivy, surrounded by a circle of Canadian wild ginger, within a larger oval of Blue Moon woodland phlox.

This garden offers a peaceful pause, providing a space for introspection and meditation. It creates an immersive experience, where visitors feel as if stepping into a secret, magical place.

The vines create shade. The woodland phlox invites bees and butterflies. The gazebo, like a green cocoon, encapsulates the visitor. Looking outward through the green invites a sense of renewed connection to nature.

The natural, timeless, organic ambiance of this garden helps the visitors reconnect to the beauty of the natural world. It provides a space to reflect on the possibilities within their own lives, encouraging them to nurture their dreams, and to approach the world feeling refreshed and rejuvenated, with a renewed sense of harmony and wonder.

The plants are native to North America, perennial, and hardy for climate zone 4B. They can be replanted elsewhere after the exhibition ends. The gazebo's natural materials (lumber and stone tiles) can be easily repurposed or recycled.

Garden of Serenity

Front Elevation
 (preliminary drawing; Nov. 2023)

Scale 1:50
 Page 2 of 4

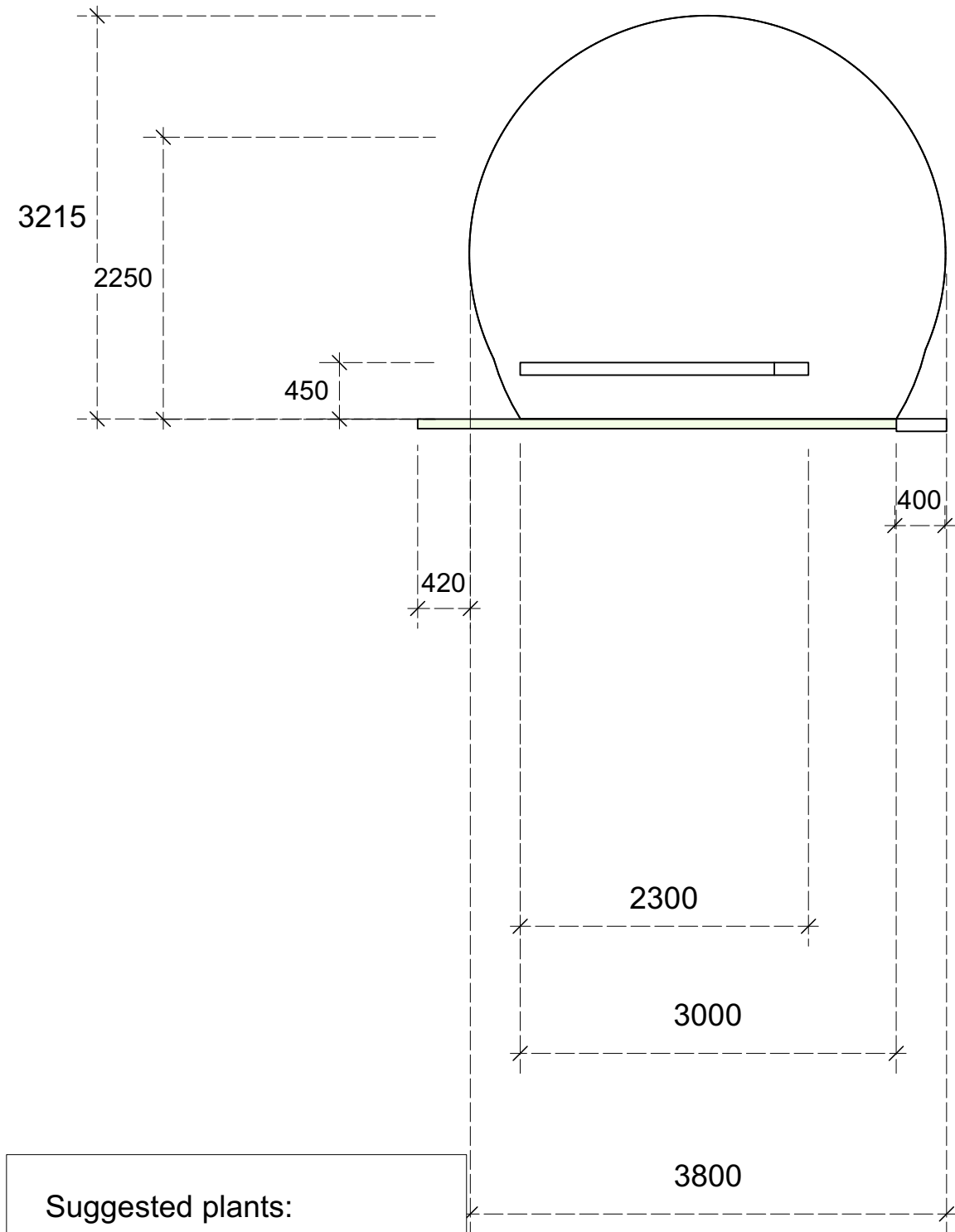

Suggested plants:
 Boston ivy;
 Canadian wild ginger;
 Blue moon woodland phlox

A gazebo covered with Boston ivy, surrounded by a circle of Canadian wild ginger, within a larger oval of Blue Moon woodland phlox.

This garden offers a peaceful pause, providing a space for introspection and meditation. It creates an immersive experience, where visitors feel as if stepping into a secret, magical place.

The vines create shade. The woodland phlox invites bees and butterflies. The gazebo, like a green cocoon, encapsulates the visitor. Looking outward through the green invites a sense of renewed connection to nature.

The natural, timeless, organic ambiance of this garden helps the visitors reconnect to the beauty of the natural world. It provides a space to reflect on the possibilities within their own lives, encouraging them to nurture their dreams, and to approach the world feeling refreshed and rejuvenated, with a renewed sense of harmony and wonder.

The plants are native to North America, perennial, and hardy for climate zone 4B. They can be replanted elsewhere after the exhibition ends. The gazebo's natural materials (lumber and stone tiles) can be easily repurposed or recycled.

Garden of Serenity
 Side Elevation
 (preliminary drawing; Nov. 2023)
 Scale 1:50
 Page 3 of 4



Suggested plants:

Boston ivy;
Canadian wild ginger;
Blue moon woodland phlox

A gazebo covered with Boston ivy, surrounded by a circle of Canadian wild ginger, within a larger oval of Blue Moon woodland phlox.

This garden offers a peaceful pause, providing a space for introspection and meditation. It creates an immersive experience, where visitors feel as if stepping into a secret, magical place.

The vines create shade. The woodland phlox invites bees and butterflies. The gazebo, like a green cocoon, encapsulates the visitor. Looking outward through the green invites a sense of renewed connection to nature.

The natural, timeless, organic ambiance of this garden helps the visitors reconnect to the beauty of the natural world. It provides a space to reflect on the possibilities within their own lives, encouraging them to nurture their dreams, and to approach the world feeling refreshed and rejuvenated, with a renewed sense of harmony and wonder.

The plants are native to North America, perennial, and hardy for climate zone 4B. They can be replanted elsewhere after the exhibition ends. The gazebo's natural materials (lumber and stone tiles) can be easily repurposed or recycled.

Garden of Serenity

Rendering

Page 4 of 4